



互联网思维下的 MOOC课程实践

清华大学计算机科学与技术系
马昱春





促进软件开发领域知识与创新的传播



关注InfoQ官方信息
及时获取QCon软件开发者
大会演讲视频信息



扫码，获取限时优惠

ArchSummit
全球架构师峰会 2017 [深圳站]

2017年7月7-8日 深圳·华侨城洲际酒店

咨询热线：010-89880682

QCon

全球软件开发大会 [上海站]

2017年10月19-21日

咨询热线：010-64738142

30年前



——原始邮件

发件人: [REDACTED]
发送时间: 2015-03-27 15:02:16 (星期五)
收件人: [REDACTED]
抄送:
主题: 【推荐信】 [REDACTED]

马老师,您好!

我是 [REDACTED], 很久没和您联系了, 不知您近来可好?

这次打扰您, 是因为有件事情想拜托您。我下学期就要去读金融的硕士研究生了。我本科期间修读了计算机辅修。研究生阶段我想继续在MOOC平台上进行一些计算机课程的学习。

Gatech这边有一个OMSCS的项目, 正好是在MOOC平台上进行计算机课程教育的项目, 所以我想申请一下。

因为不是正式的硕士项目, 所以也不会影响我之后的学业, 只是想再增长一下自己的学识。

申请这个的项目的话需要几封相关领域人士的推荐信, 所以我想问问看马老师这边是不是有可能给我写一封呢? 内容上的话我会尽力准备的。

麻烦老师啦。

顺祝春祺

附: OMSCS介绍: <http://www.omscs.gatech.edu/program/>



您是否参与过MOOC课程的学习呢？

- A 没有
- B 学过1-2门
- C 学过3-5门
- D 学过5门以上(>5)

提交



认可MOOC

奥巴马宣布MOOC将纳入美国教师培训系统

精品资讯 更新时间：2014-12-02 09:32:23 点击：384



4.5万美元。

水，下
年，身
该课
然
对目
……

【快报】奥巴马夫人：解决退伍军人就业问题，美军也要学MOOC！



玛雅蓝 MOOC学院运营小队长

2014-11-12 16:05

(文/Coursera blog) 11月10日，美国第一夫人米歇尔·奥巴马出席女性退伍军人就业峰会 (Women's Veterans' Employability Summit) 并担任发言人，宣布Coursera与美国退伍军人事务署 (Department of Veterans' Affairs, 以下简称VA) 达成合作。





COURSERA

edX

UDACITY

MIT Technology Review

Log in / Register Search

Topics+ The Daily Magazine Business Reports More+

Subscribe

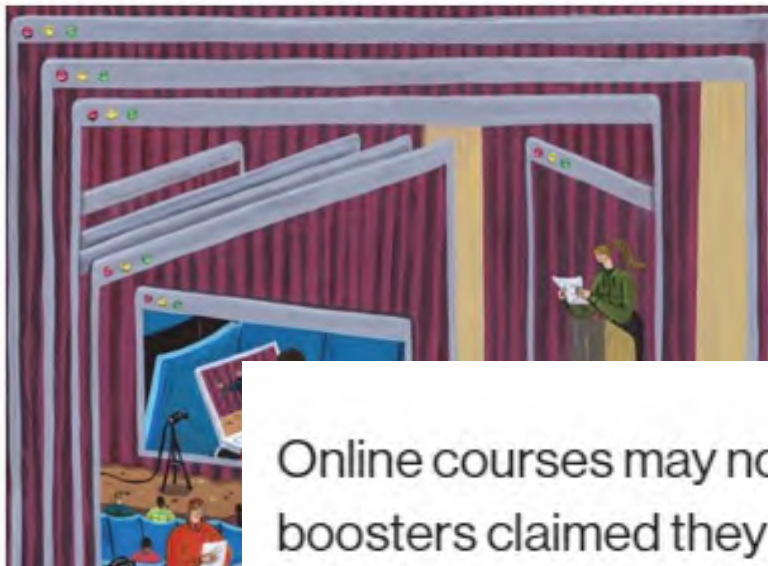

Computing

What Are MOOCs Good For?

Online courses may not be changing colleges as their boosters claimed they would, but they can prove valuable in surprising ways.

by Justin Pope December 15, 2014



Surprising ways?

MOOC is good for CS courses.

MOOC is good for humanistic curriculum.

For some people, especially adults in search of **continuing education**, even dropping out of a MOOC may well be a kind of **victory—over an old model of credit-hours and semester-long courses that makes no sense for them.**



互联网思维下的教学理念

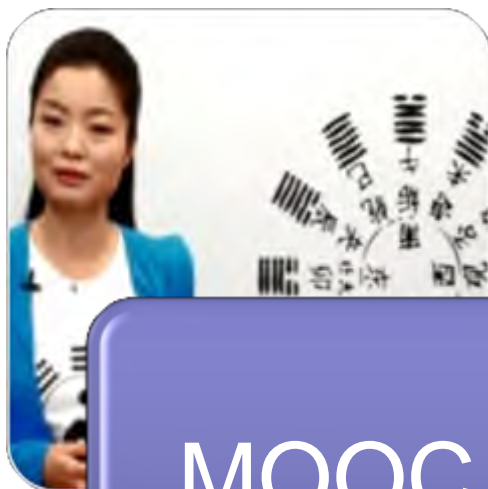

MOOC
运营设计



信息类课程的发展



学堂在线

- 《组合数学》



全部课程

组合数学 TsinghuaX 60240013X



马昱春

清华大学 计算机系 副教授

>30000学习者

edX HOW IT WORKS COURSES SCHOOLS & PARTNERS

组合数学 Combinatorics

注册信息

Number of enrollees (instructors, staff members, and students) by track

已验证	12
Audit	0
Honor	4215
总计	4227

$G(x) = (x + x^2 + x^3 + x^4 + x^5 + x^6)^m$

$\frac{1}{1-x} = 1 + x + x^2 + x^3 + \dots$



漫谈组合数学

什么是组合数学

最精巧的排列——幻方

作业 due Jun 08, 2014 at 07:30 CST

苦难的羊皮纸卷

作业 due Jun 08, 2014 at 07:30 CST

你的手机密码安全吗

作业 due Jun 08, 2014 at 07:30 CST

暴力枚举和抽象转换

作业 due Jun 08, 2014 at 07:30 CST

第一周作业

作业 due Jun 08, 2014 at 07:30 CST

第一周演示程序

小乒乓球的组合之旅

初识母函数



一一对应



我想同学们都经过了努力的思考吧

你是用什么方法得到答案的呢

8周课程

99段视频



组合数学 Combinatorics

110道作业和Quiz



以学习过程为中心的在线课堂





MOOC

学习过程为中心的在线教学体系



在线教育的大学课堂化

互联网思维的全新教学理念



互联网+

互联网思维下的教学?!





谁在学？



学习者年龄分布

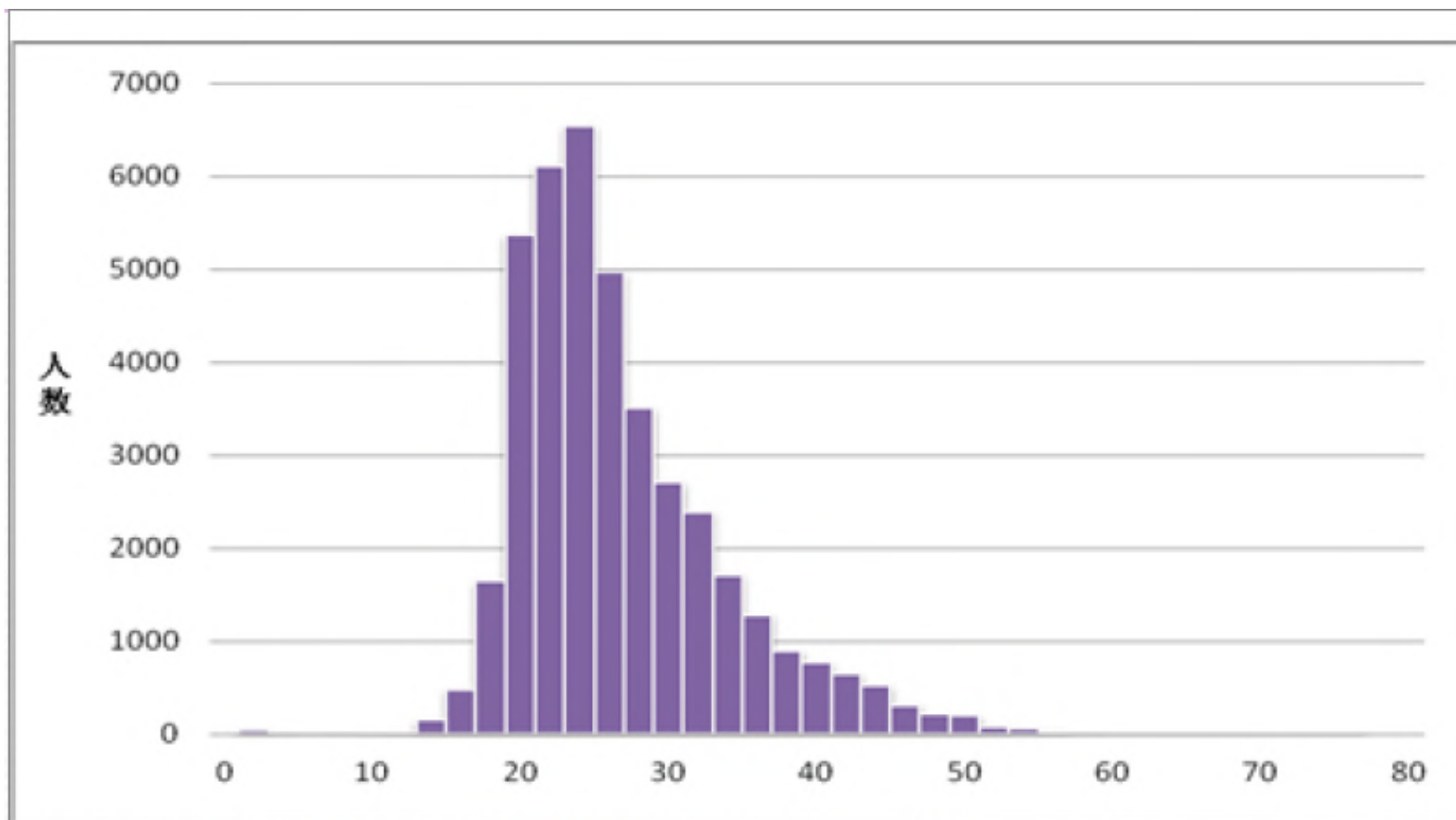

注：截止2014年1月22日，48640名学习者。下同

孙茂松 首届大中华区MOOC研讨会



地域分布

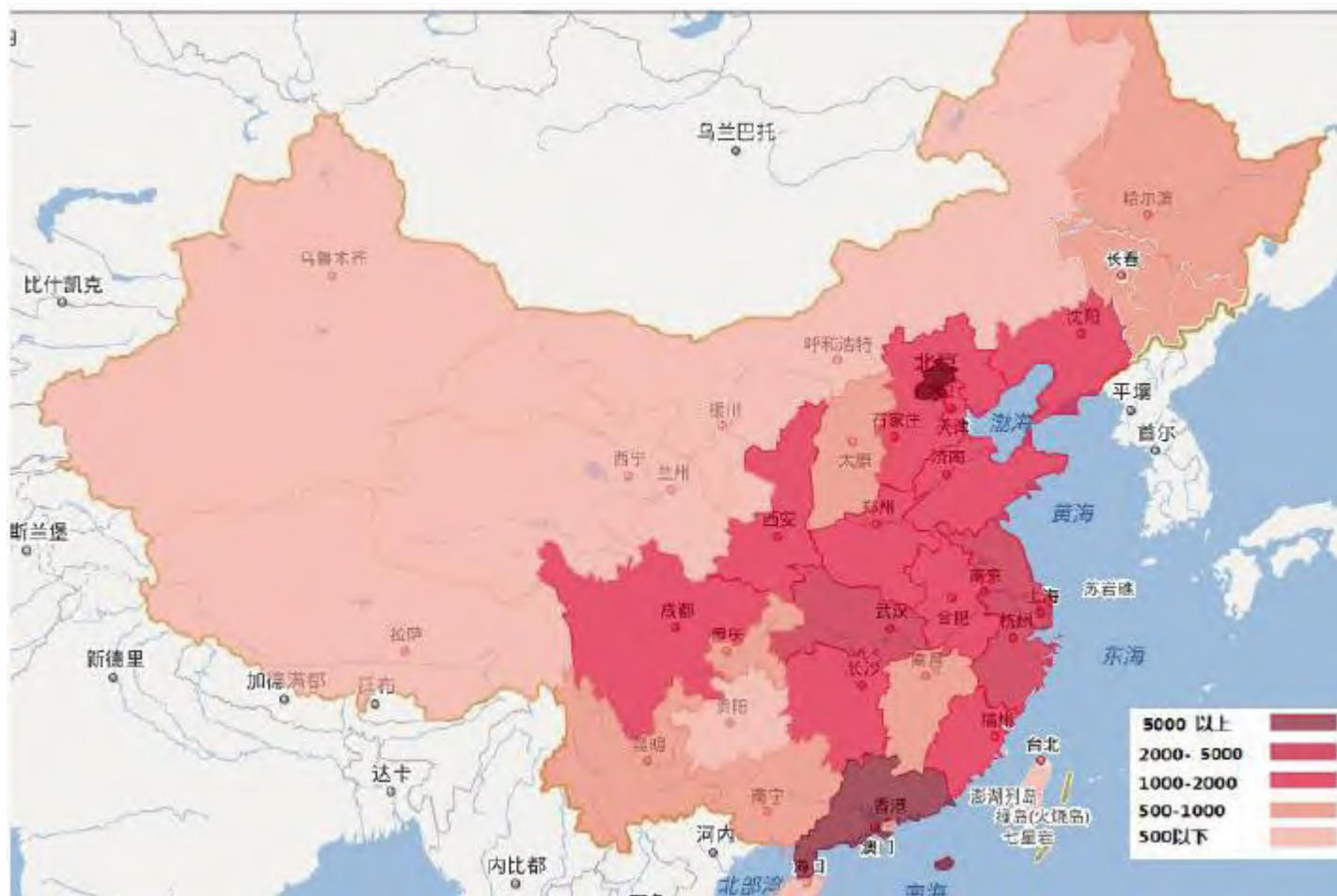



学历分布

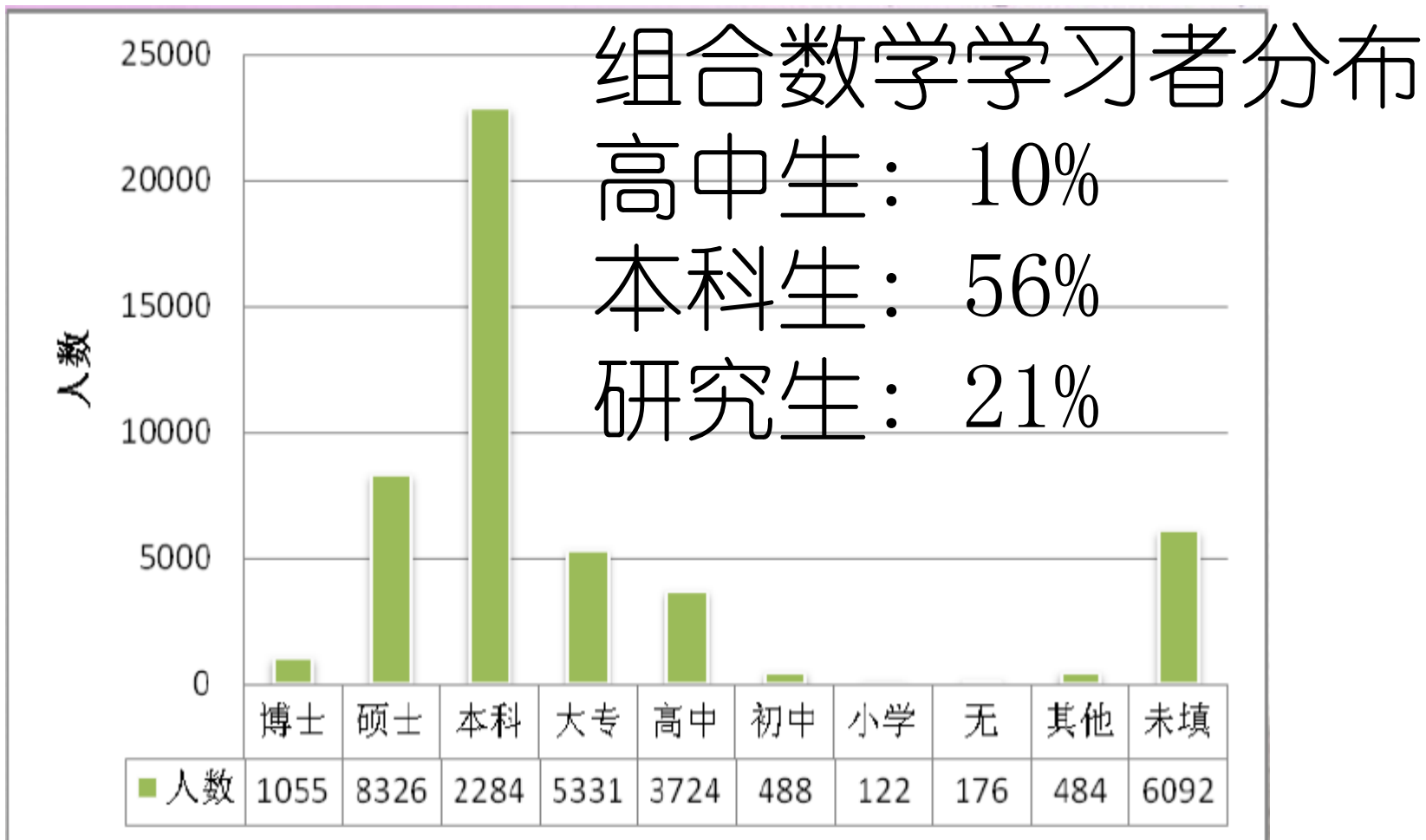



为什么学MOOC?

- 学习目的
 - 充电
 - 收获
 - 找工作
 - 证书
 -

• 组合数学课程调查

- **对数学感兴趣: 77%**
- 考研或高考: 1%
- 专业课: 4%
- 竞赛: 4%
- 工作需要: 1%
- 证书: 4%
- 对清华的课程好奇: 5%



学生眼中的数学课

- 眼一闭一睁，
黑板就满了。
- 数学课是
一个人的狂欢，
一群人的寂寞。
- 全靠数学给我的打击，
才有了现在这么坚强的自己。





教师说他们的数学课



Dan Meyer
2010年TED讲演
Math Curriculum Makeover

“I teach high school math...I sell a product to a market that doesn't want it, but is forced by law to buy it.”



MOOC来了!



“I teach high school math...I sell a product to a market that doesn't want it,



Nice to have vs Need to have

- 世间万物，难道不都是nice to have的吗？

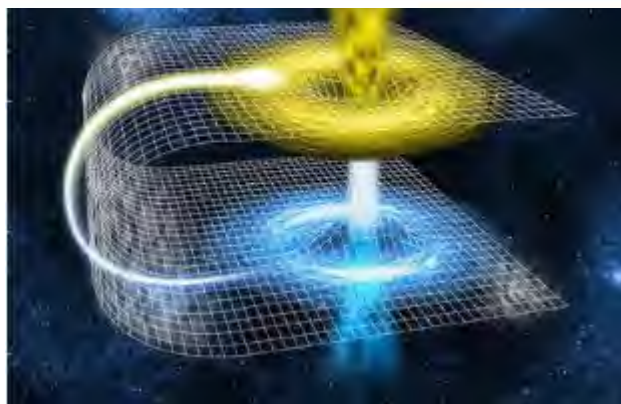
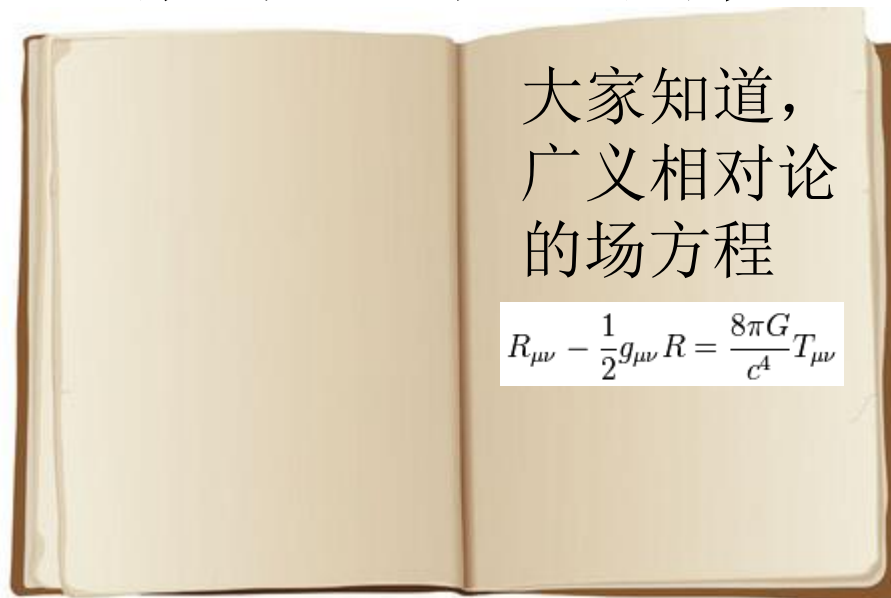



Nice Way to Have

达人推荐



lando

“ 马老师讲的非常棒。组合数学不仅是计算机学科的利器，在其他领域也有广泛的应用，老师讲解的非常清晰和有趣，练习的题目有难有易。堪称mooc必选课之一！ ”



MOOC来了

- 理念需要根本的变化
 - 碎片化
 - 知识重组
 - 游戏化

学习效率!
课程的设计和运营





思维节奏的控制

“在传统课堂上，当我提出一个问题，大概有75%的孩子还停留在对上一个问题的困惑里；15%的孩子沉浸在Facebook里；剩下10%的聪明蛋们喊出了正确答案。而我把课程放上网，上万名学生必须在同一个思考节奏上给我反馈。”



Coursera创始人Daphne Koller
斯坦福大学教授



启发式教学

- 世界杯引出的问题

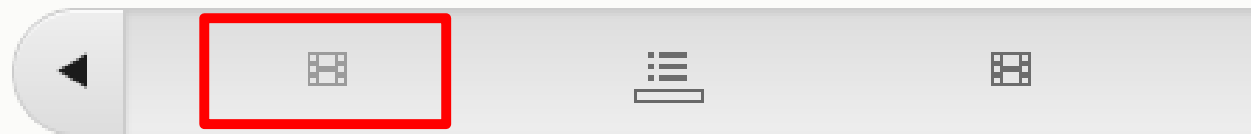

QUIZ (1 point possible)

世界杯复赛中十六支球队进行单场淘汰赛, 直至决出冠军, 若不考虑决赛阶段的第三名争夺赛, 请问一共要踢多少场比赛? () (填数字)



视频交互设计



鸽巢原理

- ◆ 已知 $n+1$ 个正整数,它们全都小于或等于 $2n$,证明当中一定有两个数是互质的。





进阶作业系统

- HUG分级作业
 - 体现了不同的知识水平和数学思维。
 - 第一部分H: 初等数学基础和简单技巧
 - 第二部分U: 具有一定的技巧性的题目，可能会需要一些高等数学概念
 - 第三部分G: 问题具有一定的开放性和难度
 - 可能会有部分思考题，思考题无确切答案，该题目不计入成绩



H U G GT 讨论区

Navigation bar with icons for back, list, search, and forward.

G1 (1 point possible)

求序列的 $\{0, 1, 4, 9, \dots, n^2, \dots\}$ 母函数

- $\frac{x}{(1-x)^2}$
- $\frac{x}{(1-x)^3}$
- $\frac{x(1+x)}{(1-x)^3}$
- $\frac{1+x}{(1-x)^3}$



MOOC的设计元素

- 围绕知识点的真实混搭



影视资料





制作MOOC的困难

- MOOC在互联网环境下任何小细节都可能被无限放大
 - 能不能及时上线? ---- 守时, 期望
 - 错误? 作业的错误 ---- 失望, 不靠谱
 - 语言教态 ---- 气场, 吸引力
 - 语音!!! ----- 最重要!

最最最重要!

习惯用语多

有口音
“那都不是事! 亮”



语音的关键

- 速度?
- 口音?



袁阔成



华少

视频播放的调速功能!!



语音的关键

让人听清楚

让人愿意听

让人听了愿意想

语言清晰

节奏抑扬

逻辑抓人



知识碎片化与系统化

Graphical Illustration of Principles of Electric Circuits

by Xinjie Yu at Tsinghua University

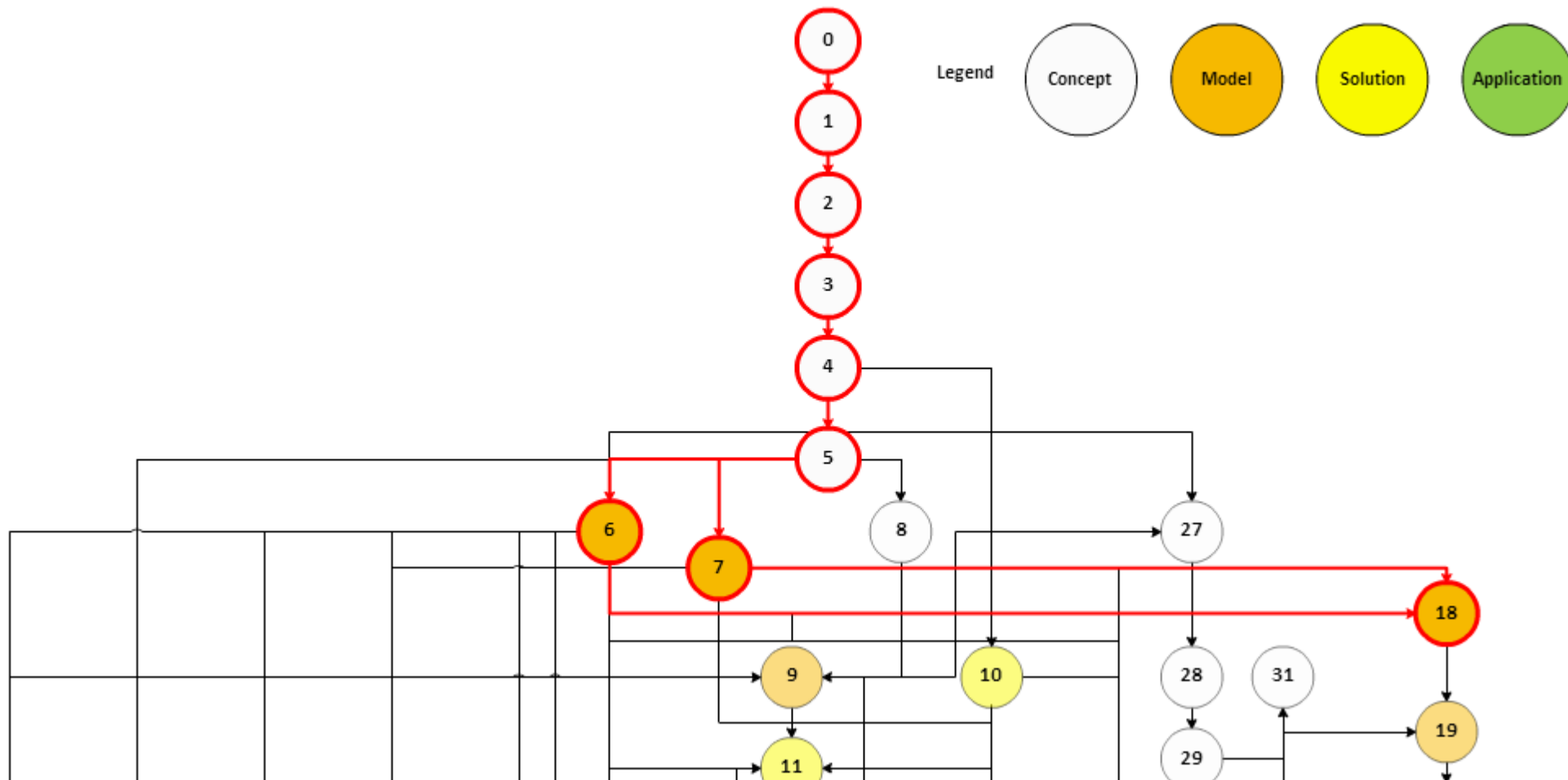



知识碎片化与系统化

- 知识点与视频片段对应
 - 知识图谱
 - 视频内容检索
 - 关键字提取





信息类课程慕课化之路

- 课程体系化
 - Micro Degree
 - 专业系列课程
 - 面向职场需求
 - 收费
- 平台智能化
 - OJ
 - 主观作业
 - 同伴互评
 - 视频内容检索

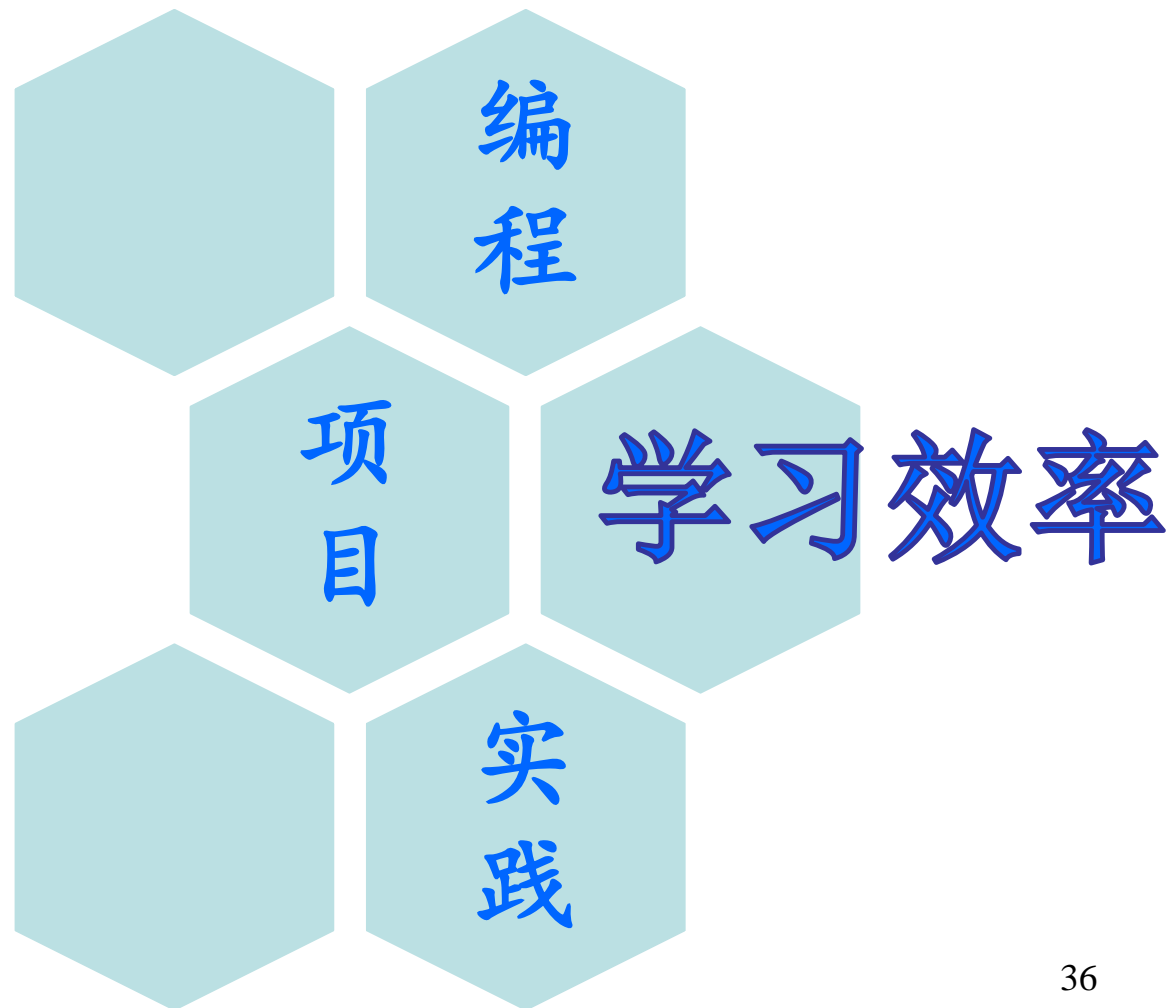



交互式学习

The screenshot displays the Codecademy website interface. At the top, the Codecademy logo is on the left, and navigation links for "Python", "Log in", and "Sign up" are on the right. The main content area is divided into several sections:

- Track progress and manage accounts:** Features a bar chart icon and text: "Easily manage user accounts and track progress with detailed analytics and reports. Give each employee their own Codecademy account, and pay for everything on a single bill." Below this are three user profile icons with progress bars.
- Build a learning plan personalized for your team:** Text: "We'll give you a personalized Learning Plan with the recommended key skills to master. You'll be able to track your progress against this plan, and add courses whenever you decide you want to learn something new!" To the right is a diagram showing a flow from a document icon to a box labeled "Skills" and then to a document icon with a checkmark. Below this are icons for a list, a folder, a document, and a refresh symbol.
- Keep learners supported and engaged with live help:** Text: "Our advisors are experienced coders who are ready to help you at a moment's notice. Contact them via live chat and they'll review your code, debug your issues, and help you get unstuck!" To the left is an icon of two people with a double-headed arrow between them, and a chat bubble icon above.

On the right side of the interface, there is a section titled "your team to learn by doing with 1000s of active lessons, projects, and quizzes". Below this are two main categories:

- Languages & Tools:** Icon shows a cube and a hand pointing to a document. Text: "Learn modern programming languages with interactive courses on the most popular tools used by developers." Below the text are the following languages and tools: Java, Python, JavaScript, Ruby, PHP, Git, Command Line.
- Data Analytics:** Icon shows a database cylinder and a Python logo. Text: "A hands-on introduction to the world of data analytics and the tool set required for data-informed decision making." Below the text are the following topics: Command Line, SQL, Analyze Business Metrics, APIs.



Micro Master



MICROMASTERS PROGRAM

RITx

Cybersecurity

Launch your career in a high demand industry that projects ...

Current



MICROMASTERS PROGRAM

UBCx

Software Development

Learn software engineering skills experts use to work in any...

Current



MICROMASTERS PROGRAM

UC San DiegoX

Data Science

Gain the critical skills needed to become a data scientist, rated...

Current



MICROMASTERS PROGRAM

CurtinX

Marketing in a Digital World

Advance your career and help your organisation succeed by...

Current



Current



Current





知乎

首页 发现 话题

搜索你感兴趣的内容...



Coursera

数据科学

Data Science 课程给 coursera 赚了多少钱?

● 添加评论 ↗ 分享 ★ 邀请回答 ...

1. 2015年共280万人报名了课程. (免费)
2. 共发出8万5千张证书 (每学一个付费课程, 可获得一张证书).
3. 500 人坚持到最后参加的 capstone project. (共91门课 + 1 capstone project)

我不知道这8万5千张证书到底发给了多少学生, 让我们假设大多数同学只学了1-2付费门课就放弃了.

Data Science Specialization Makes Coursera Millions in Revenue

Since April 2014, 1.76 million enrollments in Johns Hopkins Data Science courses



GIT online master degree program



Applications
AS OF **Spr2017**

13k



Enrollment
AS OF **Spr2017**

4515



of Countries
REPRESENTED

99



OMS/CS
News Articles

1010



有教无类，乐学致远